

CUTTERHEADS

TWINKLE CO

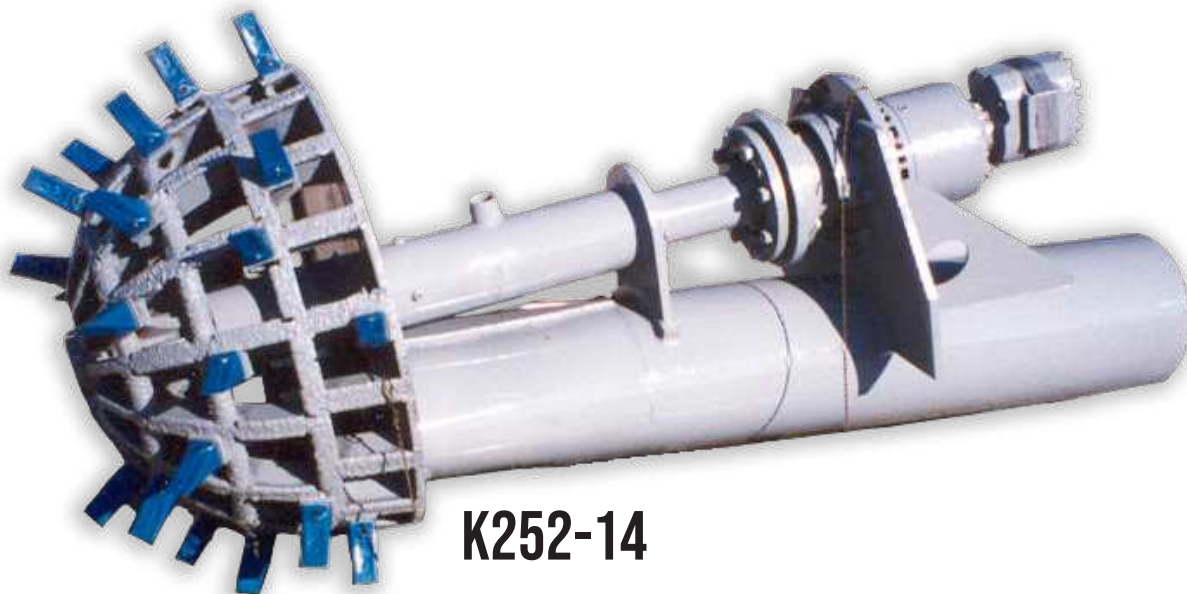

K252-14

Twinkle Co K3 & K252 cutterheads are the ideal choice for most sand & gravel dredging applications. Both the K3 & K252 feature a hydraulic motor, oil-filled sealed planetary gearbox, drive coupling, 4.5" driveshaft, marine bearing and bolt-in bearing tube, tapered basket mounting, and 3" basket retainer thread. Twinkle Co cutterhead assemblies are mounted on a length of suction pipe and ready for installation on your dredge. A static oil head tank and basket nut wrench are included.

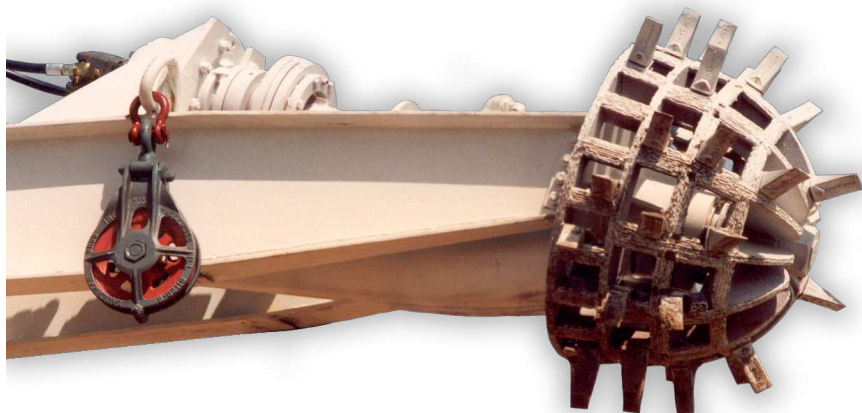
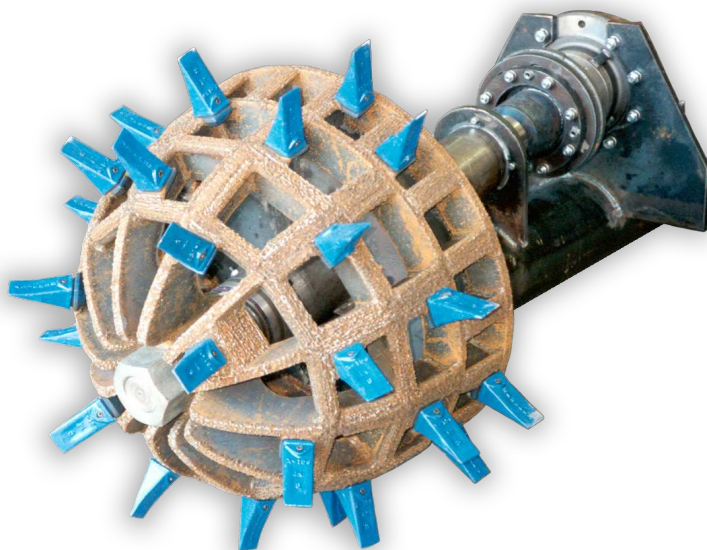

	K3	K252
Gearbox Torque Rating	75,000 lb-in	250,000 lb-in
Horsepower Rating	18 @ 15 rpm	59 @ 15 rpm

TWINKLE CO